

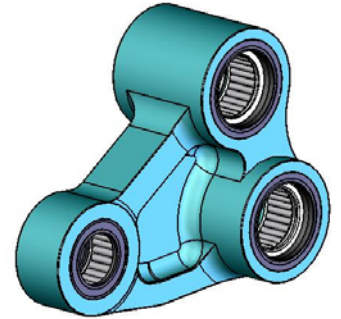

Congratulations on your purchase of Merge Racing's Honda CRF Linkage Knuckle

These instructions are intended to provide the competent mechanic with the information necessary to install this Merge product.



Product Background

The Merge Link Knuckle creates a completely new progression curve for the 2010 Honda CRF 250 and the 2009/10 CRF450 models. This product enhances handling with stock shock and units with modified damping.

Installation

Important - If you are not a competent mechanic, do not attempt to install this product yourself; have your local dealer or suspension specialist install it for you.

Precautions:

- Always wear Safety Glasses when working on a motorcycle.
- Read all safety instructions in your manual.
- Always clean the area around the rear shock before disassembly.

1. Remove OEM linkage knuckle per the owner's manual.
2. Remove the OEM center bushes and thrust washers Items shown opposite. (9 parts total)
3. Thoroughly clean all the OEM bushes and washers.
4. Grease all bearings with high load / water resistant grease.
5. Install the lower shock center bush.
6. Install the lower shock thrust washers and new seals (supplied).
7. Install the 2 larger center bushes and thrust washers.
8. Reinstall linkage knuckle on the motorcycle per the owner's manual.

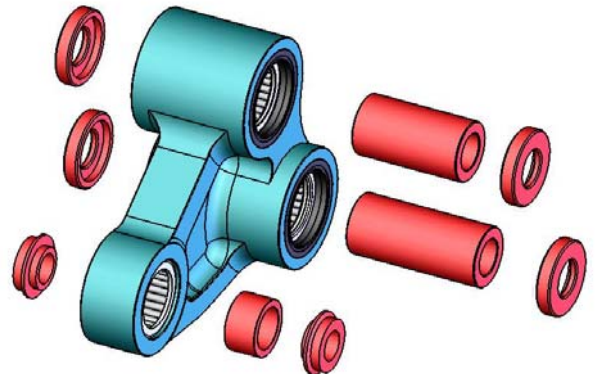

Safety Notices –

- **Offroad motorcycles should never be ridden when they are not functioning correctly.**
- **Always check nuts and bolts before riding.**

Disclaimer - Merge products are inspected prior to packaging. Our guarantee is limited to the replacement of defective products and/or components. This limited guarantee is in lieu of all other guarantees or warranties implied or expressed. Buyer assumes all risk for any and all damage caused to himself, a third party and/or property by virtue of failure of this product. We make no warranty as to products distributed by Merge Racing Technologies, expressed or implied from our suppliers or 3rd party vendors. This includes, without limitation, any warranties or merchantability and fitness for a particular purpose. All products are offered and designed for use with standard machines. Merge Racing Technologies makes no claims as to the products effectiveness on modified machines. Merge Racing Technologies is the sole determiner of abuse, misuse, installation errors and modifications. We assume no liability for any errors in listings, specifications, part numbers, prices or model applications. We reserve the right to change specifications, product descriptions, product quality, pricing and application at any time without notice and without further obligation. By installing and/or using a Merge Racing Technologies product, you hereby accept and understand these stated terms and conditions and have followed all instructional steps.

Other recommended Merge Racing Technologies products

00-030/031 "RRS" Rising Rate Springs

Visit us on the web at www.mergeracing.com

Merge Racing Technologies, 15222 King Rd, Suite #203, Frisco, TX 75034

support@mergeracing.com / sales@mergeracing.com